

OWNER'S MANUAL

SPRAYWAND P-500

PRETREATMENT APPLICATION SYSTEM



Table of Contents

Introduction	3
General specifications	3
Limited warranty	4
Safety.....	5
Safety Rules.....	5
Installation	10
Machine delivery and inspection.....	10
Machine identification.....	10
Machine location.....	10
Machine setup.....	11
Electrical service.....	11
Mechanical (gas) service	12
Burner fuel pressure.....	12
Guide to gas line pipe size	13
Venting the machine to the outside.....	14
Water supply.....	15
Initial start-up	16
Control panel.....	16
Switches	16
Pump switch.....	16
Burner switch	16
Indicator lights.....	16
Pump motor overload indicator light	16
Flow indicator light.....	16
Temp indicator light	16
Fuel indicator light.....	16
Temperature control.....	17
Initial startup procedure	18
Adjusting chemical concentration.....	19
Daily Operation	21
Starting the machine	21

Shutting down the machine	21
Winterizing the machine	22
Predictive maintenance	23
Pressure hose	23
Water inlet tank filter screen	24
Pump	24
Pump lubrication	24
Pump belt	25
High-pressure filter.....	26
Repair	28
Pump	28
Servicing the pumping section	28
Servicing the ceramic plungers and V-packings	29
Removing the pump manifold head	29
Replacing plungers	30
Replacing V-packings	31
Reinstalling the manifold head.....	31
Gas Valve	35
Adjusting the pilot light	36
Troubleshooting	37
Gas burner malfunction.....	38
Intermittent ignition device problems	39
Pump malfunction and pressure delivery problems	39
General malfunctions	41
Chemical system malfunction	41
Electrical malfunction.....	42
Service record	44

Introduction

The PEM P-500 Spraywand™ Pretreatment Application System is designed to meet the demands of high production environments. The heavy-duty system and precision fixed-ratio chemical injectors ensure consistent outputs and results.

The PEM system features chemical injection systems that are heated and ambient temperatures for many different chemical applications.



Warning: To prevent injury and equipment damage, thoroughly read and understand the contents of this manual before operating the P-500.

General specifications

Model:	P-500
HP:	7.5
Electrical:	230 V, 3 phase – 20 A 460 V, 3 phase – 10 A
Connection:	4 wire through junction box
GPM:	5
Pressure	
- Phosphatize:	1500 PSI
- Rinse:	1500 PSI
Burner output:	415,000 B.T.U.
Gas connection:	1" NPT
Fuel requirements:	
- Natural gas:	7"-9" W.C.:
- L.P.:	11" WC
Stack size:	10"
Water connection:	Standard garden hose, female swivel
Dimensions (L,W,H):	56" x 28" x 48"
Weight:	
- Dry:	575 lbs.
- Shipping:	600 lbs.
Nozzles:	1-15085 x ¼ NPT Chemical 1-40100 x ¼" NPT Rinse

Note: The manufacturer reserves the right to make improvements in design and/or changes in specifications at any time without incurring any obligation to install them on units previously sold. Some photos and/or illustrations may not be exact representations of your particular machine; however, the technical information will apply.

Limited warranty

PEM Corporation warrants each machine sold by us to be free from manufacturing defects in normal service for 90 days commencing with the delivery of the machine to the original owner.

If the machine is used with approved products, the warranty is extended to two full years or 2000 hours, whichever occurs first.

Two (2) Years Parts

- Heating Coils
- Frames
- Pump Drive Assemblies
- Coil Wrapper

One (1) Year Parts

- Electric Motor
- Gas Valve
- Pulleys
- Burner Tray

Ninety (90) Days Parts

- Lights
- Wand
- Trigger gun
- Ignition module
- Unloaders
- Coil wrapper

Our obligation under this warranty is expressly limited at our option to the replacement or repair by our company approval, or a service facility designated by us, of such part or parts as inspection shall disclose have been defective. This warranty does not apply to defects caused by damage or unreasonable use (including failure to provide reasonable and necessary maintenance) while in the possession of the consumer.

This warranty does not apply to nozzles, V-belts, hoses, pump wear parts, filters or O-rings or damage to the wand or gun due to mishandling.

PEM Corporation shall not be liable for consequential damage of anything, including but not limited to the consequential labor costs or transportation charges in connection with the replacement or repair of the defective parts.

PEM Corporation makes no warranty with the respect to trade accessories. They are subject to the warranties of their manufacturers.

Any implied or statutory warranties, including any warranty of merchantability or fitness for a particular purpose are expressly limited to the duration of this written warranty. We make no other express warranty, nor is anyone authorized to make any on our behalf of PEM Corporation.

*Heating coil warranty covers manufacturer's defects. This does not cover coils being frozen and split. Warranty does not cover coil degradation due to customer's water quality. All coils will be subject to inspection to be determined for warranty consideration by manufacturer.

Safety

This safety alert symbol indicates important messages in this manual. When you see this symbol, carefully read the message that follows, and be alert to the possibility of personal injury or death if you do not adhere to the requirements of the safety message. Also be review and follow the safety decals on the machine.

Note: PEM Corporation encourages the use of environmentally friendly chemicals and waste storage and disposal practices. Always store and/or dispose of chemicals in a manner that complies with local, state and federal regulations. Furthermore, always read and follow the directions printed on product labels when using chemicals.

Safety Rules

PEM Corporation cannot anticipate every possible circumstance that might involve a potential hazard. The warnings and cautions in this manual are therefore not all inclusive. If you use an operating procedure, installation or work method not specifically recommended, you must satisfy yourself that it is safe for you and for other persons. You must also ensure that the product will not be damaged or made unsafe by the procedure that you use.



Warning: Fluids under pressure spray can be nearly invisible and can penetrate the skin and cause extremely serious injury. Avoid contact with high pressure spray. Specifically:

- Never point the spray gun at any part of your body or at any other persons.
- Never put your hands or fingers over the spray tip while the machine is in operation.
- Never use your hands to stop or detect leaks.
- Always shut off the machine and trigger the pressure gun to relieve system pressure before removing the spray tip or servicing the machine.
- Always wear full eye protection (preferably a face shield), protective clothing and rubber boots when operating the machine to protect you from burns caused by hot spray, fluid injection or debris dislodged by high-pressure spray.

If any fluid appears to have penetrated the skin, get emergency medical care at once. Do not treat as a simple cut. Tell the doctor exactly what was injected. For treatment instructions, have your doctor call the **National Poison Control Network at 412-681-6669**.



Warning: Operate and maintain the machine in a manner that prevents injury to you and others and damage to equipment. Specifically:

- Never alter or modify the equipment.
- Never exceed the factory pressure or temperature rating of the system. Be sure all accessory equipment and system components used will withstand the pressure developed.
- Never let the pump or burner run without water supply flowing through the unit.
- Never attempt to run or relight the burner if ignition does not take place the first time. Unburned gas, which may cause a fire or explosion, may have accumulated.
- Never allow children or any unauthorized or untrained persons to operate, adjust or repair this machine.
- Always keep other persons at a safe distance when using this machine.
- Never attempt to clean or wash down the machine using its own spray gun. Cleaning the machine in this manner will increase the hazard of electrical shock and/or damage to the machine. The machine is water resistant but not water proof.

- Never leave an operating machine unattended. Always shut off the machine and relieve pressure before leaving the machine.
- Never spray inflammable or toxic liquids or chemicals such as insecticides or weed killer.
- Never operate the machine when combustible fumes or dust may be present.
- Never use detergents that are not compatible with the discharge hose. Read and follow instructions provided by the detergent manufacturer. Also follow directions on the container regarding contact with the eyes, nose or skin.
- Always provide approved vent stacks if the machine is to be used in an enclosed area. Exhaust fumes contain odorless, invisible gasses that can kill without warning. Comply with all federal, state and local codes for locating, venting and using the machine in an enclosed area.
- Always connect the machine to the correct electrical supply outlet. Comply with all federal, state and local codes and ordinances regarding electrical requirements.
- Never allow electrical extension cord connections to fall or lay in water. Use only extension cords rated for use with this machine.
- Always respect and be alert for the potential hazards of electrical equipment, hot burners, moving parts, high-pressure spray and steam.
- Always be certain that the machine safety decals are kept clean and legible. Replace any decals that become damaged, lost or painted over.
- Always disconnect the electrical plug before performing any repairs or service on machine.
- Never attempt repairs or modifications that you do not understand. Contact your service dealer or contractor.
- Always keep protective guards covers and shields in place. Replace any that were removed for service or that were damaged before operating the machine.
- Always use a gas regulator of the specified type on LP tanks for butane or propane-fired machines.
- Never exceed the 210° F temperature setting for hot water, high-pressure cleaning. Be sure the correct nozzle is used.



Danger: Chemicals used for cleaning are dangerous. Keep all chemicals out of reach of children and untrained adults. Take proper safety precautions before handling any chemicals. Read and follow all directions and instructions on the product label as well as the safety data sheets before using the chemical. Wear eye protection and rubber gloves when handling or using chemicals. Always have a clean supply of water available to wash off any contact with the skin or eyes. Should any chemical contact the eyes, immediately flood the eyes with clean water and seek medical attention at once. If skin contact occurs, flood the affected area with plenty of water for 15 minutes. If irritation persists, seek medical attention. If chemicals are swallowed, follow the product label directions and get immediate medical attention.



Warning: Do not start the machine unless you have the trigger gun or wand assembly completely under your control. Left loose, the gun or wand could recoil and damage property or cause injury.



Warning: The discharge hose supplied with the machine is designed for use on steam and high-pressure cleaners. Special care, handling, and maintenance are required to provide proper and safe operation. Follow the guidelines to ensure safe operation and maximum hose service life:

- Never exceed rated machine pressure or temperature.
- Do not route the hose in a manner that will cause sharp bending, kinking, cutting, abrasion or exterior damage.
- Do not pull on the hose to move the machine, untangle knots or pull excessively or cause stress on the hose.

- Do not use the hose if cuts, leaks, abrasions, bulges or coupling damage is evident.
- Do not use the hose if any reinforcement is exposed.
- Do not attempt field repairs through an unauthorized hydraulic hose repair shop. Special couplings and crimping specifications are required for steam and high-pressure washer discharge hose. Contact a qualified pressure washer service representative for repair of damaged hose. If you have any doubt about the hose condition, replace it immediately.
- Always examine hose couplings and the quick disconnect (if provided) before each operation. If leaking is evident, do not use the hose. Contact a qualified pressure washer service representative.
- Never leave the discharge hose lying on the floor or ground to be driven over by vehicles or damaged by falling objects. Always coil and hang the hose immediately after use.



Danger: To prevent unexpected energizing, startup or release of energy that could cause injury to people working on the machine follow the steps of the OSHA Lockout/Tagout Rule below to ensure that power to the machine will be under control:

1. Turn off the equipment.
2. Dissipate or release all residual energy in the machine.
3. Shut off the main power cord near the machine, and tag the switch.
4. Check all previous steps, and then try to operate the machine to ensure that it won't work.

Installation

Machine delivery and inspection

Before unpacking, check the machine for any damage that may have occurred during shipment. Note any damage and immediately contact the carrier to make a damage or shortage claim.

Machine identification

The machine model number, serial number and specifications are stamped on an identification plate that is permanently attached to the right rear side of the machine main frame. See Figure 1.

For future reference, record the information from this plate in Table 1.



Figure 1: Identification plate location on the right side of the control panel.

Model _____

Output _____ Gpm _____ Psi _____

Fuel _____

Elec. _____ Ph _____ Volts _____ Amps _____

Serial Number _____

Table 1: Machine identification from the plate.

Machine location

The gas-fired pressure cleaners are designed specifically for use as stationary unit in a well-ventilated area. Position the machine for easy and safe access to controls, power, water, and fuel supplies. Also consider the best possible location for access to the machine for routine maintenance or service.



Danger: Do not locate the machine in a small, enclosed area. Without adequate ventilation, incomplete combustion carbon monoxide and overheating will result. Carbon monoxide can cause death.

If the machine must be located out of sight of the operator, special equipment or controls may be required to provide proper operation and ensure operator safety. Contact your dealer or qualified service representative before installing or using the machine from a remote location.

Avoid locating the machine in direct spray; the SprayBay® is not an appropriate location for this equipment.

Avoid locating the machine on slippery surface areas or where water may accumulate.



Danger: Do not locate the burner where fumes, dust, or other flammable materials may be present.

Machine setup

Exact machine setup may vary somewhat between machine models; however, the following information will be a general guideline. Contact your dealer or authorized service representative for special installation or setup requirements.

Note: In order to avoid unnecessary expense of complying with or correcting the violation of a regulation, investigate all applicable state and local codes before attempting to install the machine.

Electrical service



Caution: Do not attempt to operate this machine on less than 90% of rated system voltage. Overheating, poor performance or component damage could occur. Contact a qualified electrical technician to check for proper system voltage.

Note: The pump is designed to operate in either direction; rotation direction is not an issue.

Refer to the machine date plate to determine the exact electrical supply requirements for your machine. Be sure all machine control switches are turned off before connecting the electrical supply.

To further ensure machine grounding, a separate external grounding lug has been provided. It is located below the nameplate. In certain areas, it is either recommended or required that a separate ground wire be attached to this lug and to an available ground source, such as a metal water line or ground rod. (See Figure 2).

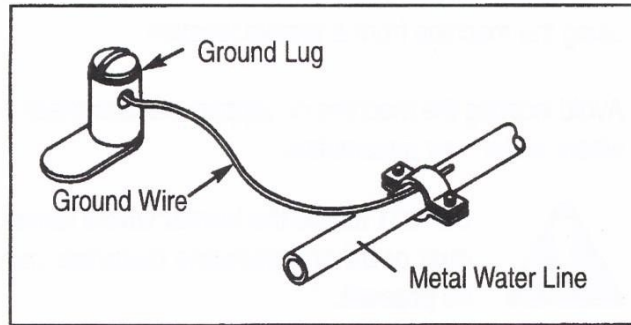

Figure 2: Ground

The electrical supply must be connected directly to the electrical service supply box on the machine. Electrical connection and supply for these machines must be made by a licensed electrician and must conform to all federal, state and local codes and ordinances regarding three-phase electrical requirements.

Mechanical (gas) service

Have a HVAC expert set up gas connections.

Burner fuel pressure

Adjust the pressure to the type of burner fuel as follows:

Natural gas-fired machines:

Operate on 3 ½" of water column (2 oz.) pressure after the valve and must have from 7" to 9" water column (3 to 4 oz.) pressure supplied to the gas valve at the inlet. The water column check points are as follows:

Check the water column pressure at the valve with the burner operating.

The Spraywand is not equipped with a gas regulator, so a regulator will need to be installed in the gas line before the gas valve. This will allow for the adjustment in gas pressure.

Liquid Propane fired machines:

Operate on 11" (3.6 oz.) water column pressure. This propane (LP) gas machines are not equipped with a gas regulator. Therefore, install on the LP tank a gas regulator (see Figure 3) of sufficient size to allow for pressure drop from the tank to the machine.



Figure 3: Gas Regulator



Warning: Maximum inlet gas pressure is 0.32 PSI (14" water column or an 8.9 oz. per square inch).

Install a gas shutoff valve in back of the machine on the gas line with a union between the valve and the gas regulator (see Figure 4). Prior to operating the burner system, purge the new lines. If this is not done, starting the burner can be difficult.

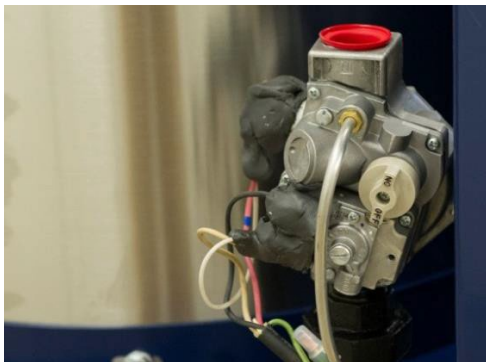

Figure 4: Gas Valve

Guide to gas line pipe size

See Table 2 for the minimum gas line iron pipe size required for gas supply per length of gas line from the valve side of the meter (Natural Gas) or valve is based on a pressure drop of 0.03-inch water column pressure and 0.60 specific

gravity. See your gas supplier for assistance if your system has many fittings or unknown loads.

Pipe length (feet)	Pipe diameter (inches)
10'	$\frac{3}{4}$ "
10' – 30'	1"
30' – 125'	1 $\frac{1}{4}$ "
125' – 200'	1 $\frac{1}{2}$ "

Table 2: Minimum gas line iron pipe size

Venting the machine to the outside



Caution: Chimney stacking for the burner venting should be made by a licensed technician and conforms to all federal, state and local codes regarding burner ventilation.

In northern locations, ensure provisions are made to prevent cold down (negative pressure) drafts from freezing the coil when the machine is not in use. Install UL listed weather cap (on top of the building).

If the machine is used in an enclosed area and you are putting a chimney on it, be sure a draft diverter (see Figure 5) is installed and the chimney is as at least the same size as the stack on the machine (10 inches).

Poor draft will cause the unit to soot and not operate efficiently. Position the machine to ensure the straightest stack possible.



Figure 5: Draft diverter. It is installed just above the burner.



Caution: Never reduce the size of the stack. Do not retrofit to a smaller stack. If the stack is restricted, there the machine will have enough air movement.

Water supply

Connect the machine to a cold-water supply tap in the back of the machine (see Figure 6). The water supply must equal to at least 1.5 times the gallon per minute (gpm) output of the machine. If wide variations in water pressure occur, install a pressure regulator in the supply line. Use at least a 3/4-inch ID supply hose.



Figure 6: Water connection in the back of the machine



Caution: To prevent machine damage, use only perfectly clean water. If the water supply exceeds 6 grains of hardness (100 ppm), the coil conditioner will extend the coil life and maintain machine efficiency.

Initial start-up

Control panel



Warning: To assure safe operation, familiarize yourself with the machine controls and indicator lights before starting or operating the machine. See Figure 8.

Switches

Pump switch – This switch will start the pump operation. Turn on this switch to start the pump motor. Turn off this switch to shut down the entire machine, including the burner.

Burner switch – This switch will turn on the igniter, which lights the pilot light. During normal operation, turn off the burner switch to shut down the burner, and let the coil cool down before shutting off the Pump switch.

Indicator lights

Pump motor overload indicator light – This light will glow orange if the pump motor overload protector switch has tripped because the machine has drawn too many amps. This may indicate the wiring to the motor or the motor itself is faulty. If the indicator light turns on, turn off the pump switch and let the machine cool down. Turn the pump switch on again. If the pump motor continues to shut down, call P.E.M.

Flow indicator light – This light will glow red during normal operation when the gun trigger is pulled, indicating the circuit through the flow switch is good. It will turn out when the gun trigger is released. If the light remains out when the trigger is pulled, it may indicate faulty flow switch or wiring.

Temp indicator light – This light will glow red during normal operation and indicates the pilot light is lit and the thermostat-controlled circuit through the temperature control switch is complete. The light will go out during normal operation whenever the water temperature reaches its preset limit setting (when the thermostat shuts off the circuit).

Fuel indicator light – This light will glow red during normal operation and indicates the circuit to the gas valve is complete. It will stay on whenever the

burner rocker switch, which controls gas flow to the burner, is on (when the wand trigger is pulled).

Temperature control

Located to the right of the indicator lights, this knob (Figure 7) is turned to set the water temperature (210° F Max). The burner will cycle on and off to maintain the selected water temperature.



Caution: Left loose, the gun or wand assembly could damage and cause injury to personal or property damage. Do not start the machine without having the trigger gun or wand completely under your control.



Caution: Never run the cleaning unit dry. Costly damage to the pump will result. Always be sure the water supply is completely turned on before operating the machine.



Figure 7: Control panel

Initial startup procedure

1. Inspect connections for any leaks and tighten if necessary.
2. With the nozzle removed from the wand, turn on the Pump switch to start the pump.
3. Run the machine for 1 minute. Operate the trigger once or twice.
4. Shut off the machine and install the nozzle.
5. Check for high pressure leaks, and tighten connections if necessary.
6. Operate the trigger mechanism to make sure the unloader valve that operates the system is full of water.
7. Turn the gas valve in back of the machine on.
8. Turn on the fuel source. Check the thermostat setting.
9. Turn on the Burner switch. Once the burner switch is turned on, the pilot will attempt to light. The ignitor will try to light three times. Allow time for the gas to get to the pilot. The burner switch may need to be activated a few times to bleed the pilot line.

The ignition module will go into lockout mode after 15 seconds of not lighting. To reset the ignition module, you will need to turn the burner switch off and back on. Continue to do this until the temp light illuminates. This indicates the pilot valve solenoid is open and the igniter switch activated the pilot light. The Temp light will come on. The system is ready to fire.

Note: The system has series of safety checks that must be satisfied before the Temp light comes on. If the Temp light is not on, the burner will not fire. If the Temp light does not come on, refer to the Troubleshooting section.

Note: The igniter will light the pilot automatically when the Burner switch is turned on. However, the burner only lights when the wand trigger is pulled.

10. When the Temp light is lit, which indicates the burner system is ready, pull the wand trigger to activate the burner. The Flow light will light.

Note: The gas control valve has a delay feature. It takes 4 to 7 seconds for the burner to light after pulling the wand trigger. If the burner does not light, refer to the Troubleshooting section.

11. After pulling the wand trigger for 30 seconds to operate the burner, test the flow switch by releasing the wand trigger. Confirm the burner extinguishes immediately (you will be able to see that flame go out).



Caution: If the burner does not go off, hold the trigger on the gun open, and shut the gas supply to the machine. Continue to hold the trigger until the burner extinguishes, and then turn the Pump switch off. This will prevent damage to the machine. Do not attempt to restart the machine, and contact PEM.

Ph: 507-345-1512

email: sales@pemequip.com

Adjusting chemical concentration

To apply acidic cleaners, a downstream injector is used, which is specifically designed for the system. The injector itself is precision calibrated and non-adjustable. However, the ratio of chemical-to-water is easily adjusted using the color-coded metering orifices that can be threaded into the chemical pick-up. An assortment of various sized metering orifices is included with the machine in the instruction packet. See Table 3. The injector will draw approximately 2.5% chemical with no metering tips. The metering tips can be used to reduce this percentage in 0.2% increments down to approximately 0.8 percent. These metering tips thread into the chemical barb on the injector. Install them as follows:

1. Slip the vinyl pick-up tube off the barb
2. Thread the selected metering tip into the injector barb.
3. Replace the vinyl tube.

Purple	2.00%
Black	1.60%
Yellow	1.40%
Blue	1.20%
Green	1.00%
White	0.80%

Table 3: Metering orifices

*Superflow Injectors are also available. These injectors can produce higher chemical concentrations up to 4%.



Caution: Chemicals not compatible with the system materials will cause damage to the components down the line from the chemical injector. Ensure the chemicals will not damage stainless steel, Burna-N, and Viton.



Warning: High-pressure spray, detergents, fluid injector or debris dislodged by the high-pressure spray can cause burns or other types of injuries. To protect yourself, always wear full eye protection (preferably a face shield), protective clothing, rubber gloves, and boots when operating the machine.



Danger: High pressure spray can damage the machine and cause electrical shock. Never attempt to clean or wash down the machine using its own spray gun. The machine is water protected but not water proof.

Daily Operation

Starting the machine

1. Turn on the pump switch.
2. Turn on the burner switch.

Note: The pump is designed to operate in either direction; rotation direction is not an issue.



Caution: To prevent damage to the machine, follow the steps in the Maintenance section.



Caution: Do not let the pump run dry. Serious damage to the machine will occur. Always ensure continuous water flow to the machine.



Caution: Never adjust or modify the unloader valve, which is located next to the pump and is used to bypass the coil when the wand is not in use. Adjusting the unloader valve will not increase performance of the unit and will void the manufacturer's warranty.



Caution: Do not drag the hose over an abrasive surface such as cement. This will cause excessive wear and shorter hose life. Lift the hose up instead of dragging it.



Caution: To prevent injury when removing and installing nozzles, use only spray tips that are matched to the unit. Keep the nozzle and the tube pointed away from you and others.

Shutting down the machine

1. Turn off the Burner switch, and let the heating coil cool down.
2. Turn off the Pump switch.

Winterizing the machine



Caution: Do not store the machine where it will be subject to freezing temperatures, otherwise severe damage will occur. If it must be stored where the temperature is below 32° F/0° C, winterize the machine as follows:

1. Prepare 10 gallons of 50/50 antifreeze and water.
2. Remove the nozzle from the wand, and lay out the hose and wand flat on the floor.
3. Drain the float tank, and refill it with the antifreeze solution.
4. Hold open the trigger gun while keeping the float tank full of the antifreeze solution.
5. Turn the Pump switch on. When antifreeze solution appears at the end of the gun, release the trigger once or twice, and then turn the Pump switch off.
6. When preparing to operate the machine the next time, have an antifreeze container handy. Reconnect the water supply. Turn the Pump switch on, and direct the flow of antifreeze into the container, taking care not to dilute it when water starts flowing through. Antifreeze left undiluted can be reused.

Predictive maintenance



Warning: To prevent damage to the machine and injury of personnel, make daily inspections of the machine for anything that could cause damage, fire or any other safety problem.



Warning: To prevent injury from electric shock or accidental machine startups, disconnect the electrical power supply before servicing any part of the machine. Follow lock-out, tag-out procedures to prevent accidental startup.

Pressure hose

Inspect the hose for wear or damage (see Figure 8). If there is damage, replace the hose. Do NOT repair it.

Wrap up the hose as soon as you turn off the machine, and store it on the hose hooks or other safe location.

Hose Reels will greatly increase the life of the hoses. Feel free to contact PEM about hose management options available.



Caution: Avoid extending the hose across high traffic areas, which can damage the hose. Never leave the hose where it can be run over by any type of vehicles.



Caution: Never pull the hose around a sharp corner or force it into a small lip. The wire braid has a minimum bend of 5 inches. A smaller bend will damage the braid.

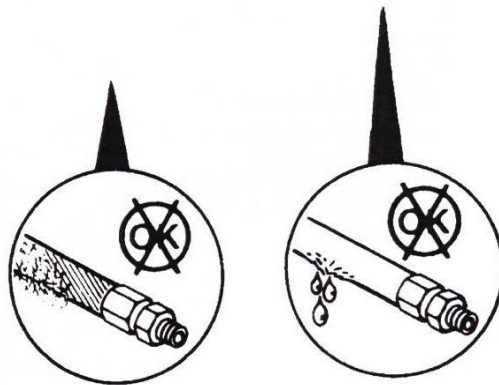

Figure 8: Examples of a damaged hose

Water inlet tank filter screen

The stainless-steel screen located in the float tank (see Figure 9) prevents foreign material from entering the pump. Check the screen frequently to ensure that it does not clog.



Caution: To prevent damage, never operate the machine with the filter screen removed. Be sure to put the filter in place after cleaning it.

Pump

Pump lubrication

The pump (see Figure 9) is pre-lubed at the factory. However, check the pump oil level frequently as follows:

1. Locate the site glass on the back side of the CAT pump. The site glass is a clear circle with a red dot in the middle: the oil level should be at the red dot. If the oil is low, remove the fill plug and add oil.
2. Fill the crankcase to the red dot on the site glass with **SAE 30 weight oil, preferably with no detergent**. Do not overfill.
3. Replace the fill plug.

Change the oil after the initial 50 hours of operation and then after every three months or 500 hours of operation, whichever occurs first. Change the oil as follows:

1. Drain the oil by 1) removing the plug located at the rear of the pump crankcase or 2) removing the fill plug (Figure 10) and suctioning the oil out with a suction gun that has a flexible tub.
2. Fill the crankcase to the red dot on the site glass with **SAE 30-weight oil, preferably with no detergent**. Do not overfill.
3. Replace the check/fill plug.

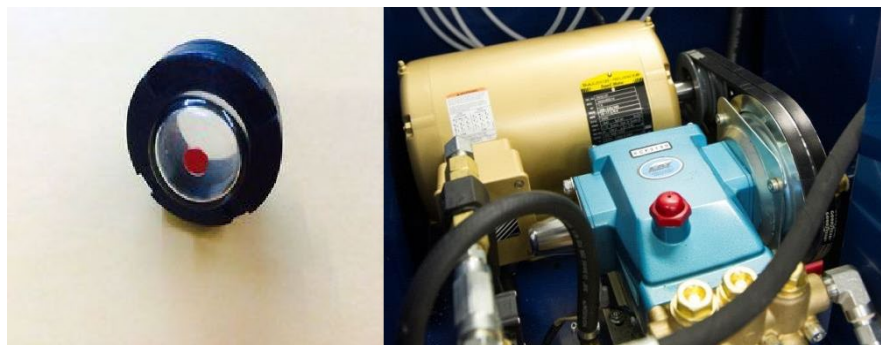

Figure 9: Pump

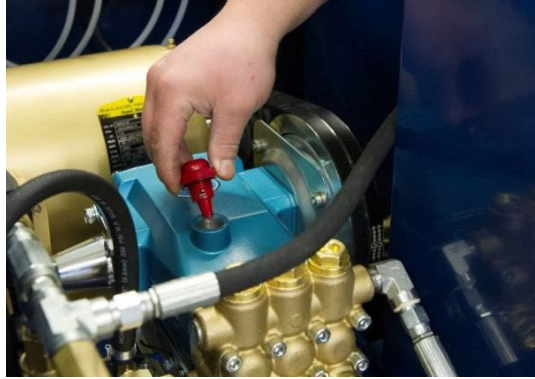

Figure 10: Pump oil check/fill plug

Pump belt

New belts will loosen after a short amount of use, and the tension must be readjusted

1. Measure belt deflection at the longest span of belt, midway between the pulleys. With a 25-lb vertical force applied, ensure the deflection is no more than 1/2" to 5/8" (see Figure 11).
2. If you are using a belt tension gauge, ensure that 100 to 110 lbs. is registered on the spring scale when the pump is secured in the operating position.
3. To adjust the belt tension, loosen the four-pump main frame attaching bolt nuts one half to one turn. Turn the tension bolt nut clockwise to tighten the belt or counterclockwise to loosen it.
4. Tighten the mount-bolt nuts.
5. Using a straight edge, verify the pump drive pulley alignment. If it is off, adjust the position of the pump by loosening the pump mounting nuts, adjusting the pump position and re-tightening the nuts.

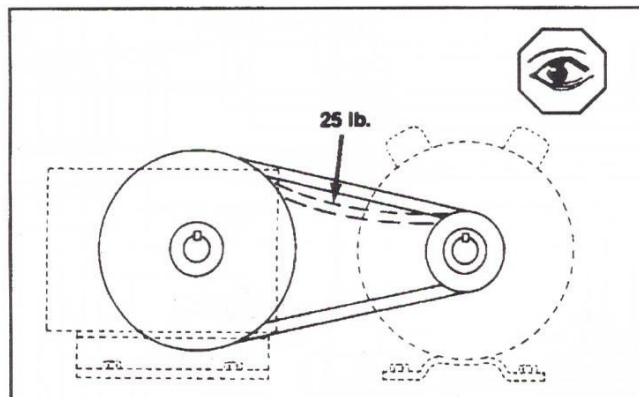

Figure 11: Measuring pump belt deflection

Inspect the belt for excessive wear, fraying and cracking at least once a month or after every 100 hours of operation, whichever comes first. Replace damaged or worn belts.

Note: Install dual pump belts in matched sets. When belt replacement is necessary, never replace a single belt in a set as the new belt will carry all the load and fail rapidly.

High-pressure filter

The machine has a high-pressure filter (see Figure 12) located in the high-pressure line before the chemical injector. It has the following specifications:

Sintered 316 stainless steel filter element

Standard micron ratings include 1, 5, 10, 50 and 100

Pressure rating:

316 stainless steel – 6000 psig CWP

Brass – 3000 psig

Temperature rating:

Viton (-15° F to 400° F)

Buna-N (30° F to 4275° F)

Ethylene propylene rubber (70° F to 275° F)

This filter traps any mineral chips or scale in that breaks loose from the I.D. of the coil. If this debris is not filtered, it could plug the orifices in the chemical injector. Service this filter weekly as follows:

1. Remove the hose from the top of the filter.
2. Remove the end cap and filter element (screen).
3. Examine the filter element for damage. Do not reinstall a filter element showing any sign of damage.
4. If the filter element is intact, clean it, lightly grease the rubber seat inside the end cap and replace the element. If the element is not intact, obtain a replacement kit (element, spring, white ring) from PEM, and replace it.

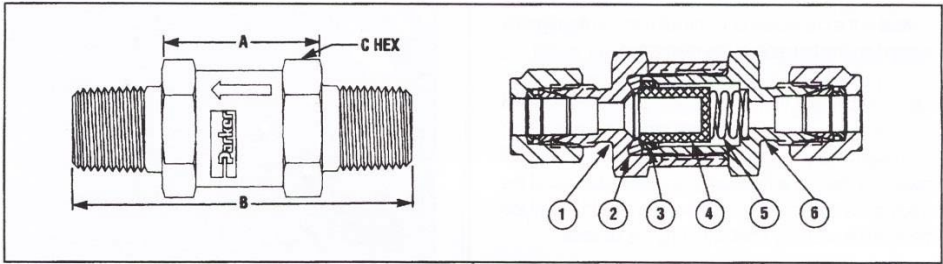

- 1-End cap
- 2-Rubber seat
- 3-White ring
- 4-Element
- 5-Spring
- 6-Body

Figure 12: High-pressure filter

Repair

Pump

Servicing the pumping section

The three inlet and three discharge valves are identical and can be serviced without disrupting the inlet or discharge piping using a valve kit available from the manufacturer. Two kits will be needed to repair all the valves in the pump. The kit includes new O-rings and a valve assemblies (valve seat, poppet, spring and retainer all preassembled). Service the valves using the kit as follows:

1. Remove each valve plug using a 24 mm socket (see Figure 13).



Figure 13: Removing valve plugs

2. Examine the O-ring gaskets, and replace if needed (see Figure 14).



Figure 14: Examining the O-ring gaskets

3. Using a needle-nose pliers, remove the valve assembly from the cavity (see Figure 15).

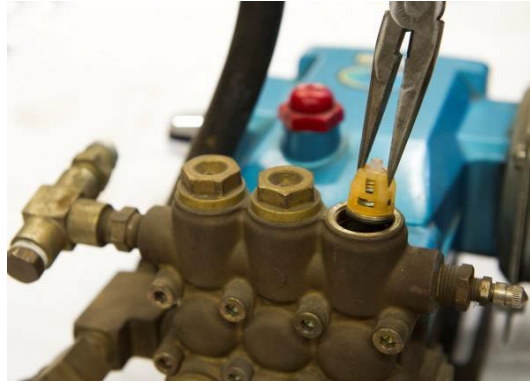

Figure 15: Removing the valve assemblies

4. Remove the O-ring from the cavity.
5. Install the new O-ring in the valve cavity.
6. Insert the new valve assembly into the valve cavity.
7. Replace the valve cap and torque it to 70-75 foot-pounds.

Servicing the ceramic plungers and V-packings

Removing the pump manifold head

1. Using a 6 mm hex-key wrench, remove the eight cap bolts from the manifold head (see Figure 16).

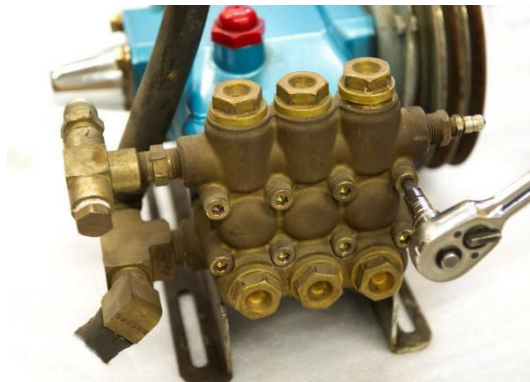

Figure 16: Removing the cap bolts

2. Separate the head from the crankcase. It may be necessary to tap the head with a rawhide mallet in order to loosen it (see Figure 17).



Figure 17: Removing the manifold head

Caution: When sliding the head from the crankcase, be careful not to damage the plungers.

3. The V-packing assemblies may come off with the head. If not, slide them off and examine the ceramic plungers. Their surface should be smooth and not scored or pitted. Clean them if necessary, and replace them if they are damaged as follows:

Replacing plungers

1. Using a 10-mm socket, remove the ceramic plunger and plunger retainer from the piston rod (see Figure 18).

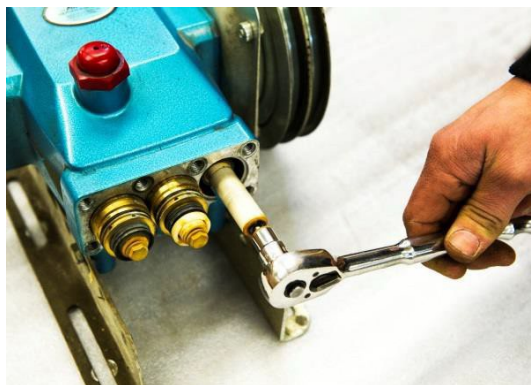

Figure 18: Removing plunger

2. If the barrier slinger or keyhole washer comes off with the plunger, replace them before installing a new plunger.
3. Separate the plunger retainer from the plunger.
4. Install a new seal washer on the plunger retainer. Use a small dab of grease on the outside of the seal washer to ensure better installation.
5. Carefully press the plunger retainer into the new plunger.
6. Slide the new plunger over the piston rod, and torque it to 5 foot-pounds.

Replacing V-packings

1. From the crankcase side of the manifold head, use a reverse pliers to remove the low pressure seal from the seal case.
2. Using the reverse pliers, remove the press-in seal case from the manifold.
3. Remove the front male adapter and the V-packing.
4. Examine the adapters and v-packing for wear, and replace as needed. Examine the seal case O-ring.
5. Install the new head ring.
6. Coat the front V-packing with a thin film of grease, and insert it in the cavity. Repeat with the second V-packing. Lubricate the seal case O-ring.
7. Firmly press the seal cases into the V-packing
8. Press the low-pressure seal into the seal case with the garter spring down.
9. Replace the seal retainer with tabs facing down and holes away from the crankcase.
10. Coat each plunger with a thin film of grease.

Reinstalling the manifold head

1. Carefully slide the manifold head into the crankcase.
2. Install the eight cap bolts as follows:
 - a. Install all eight cap bolts finger tight.
 - b. Torque all cap bolts to 5 foot-pounds in the sequence shown in Figure 19.
 - c. Torque all cap bolts to 10 foot-pounds in the sequence shown in Figure 19.

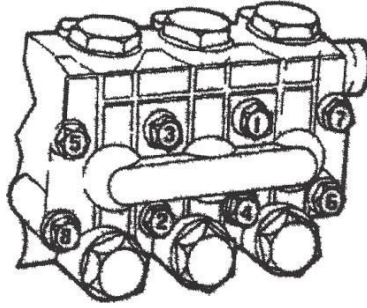

Figure 19: Manifold head torque sequence

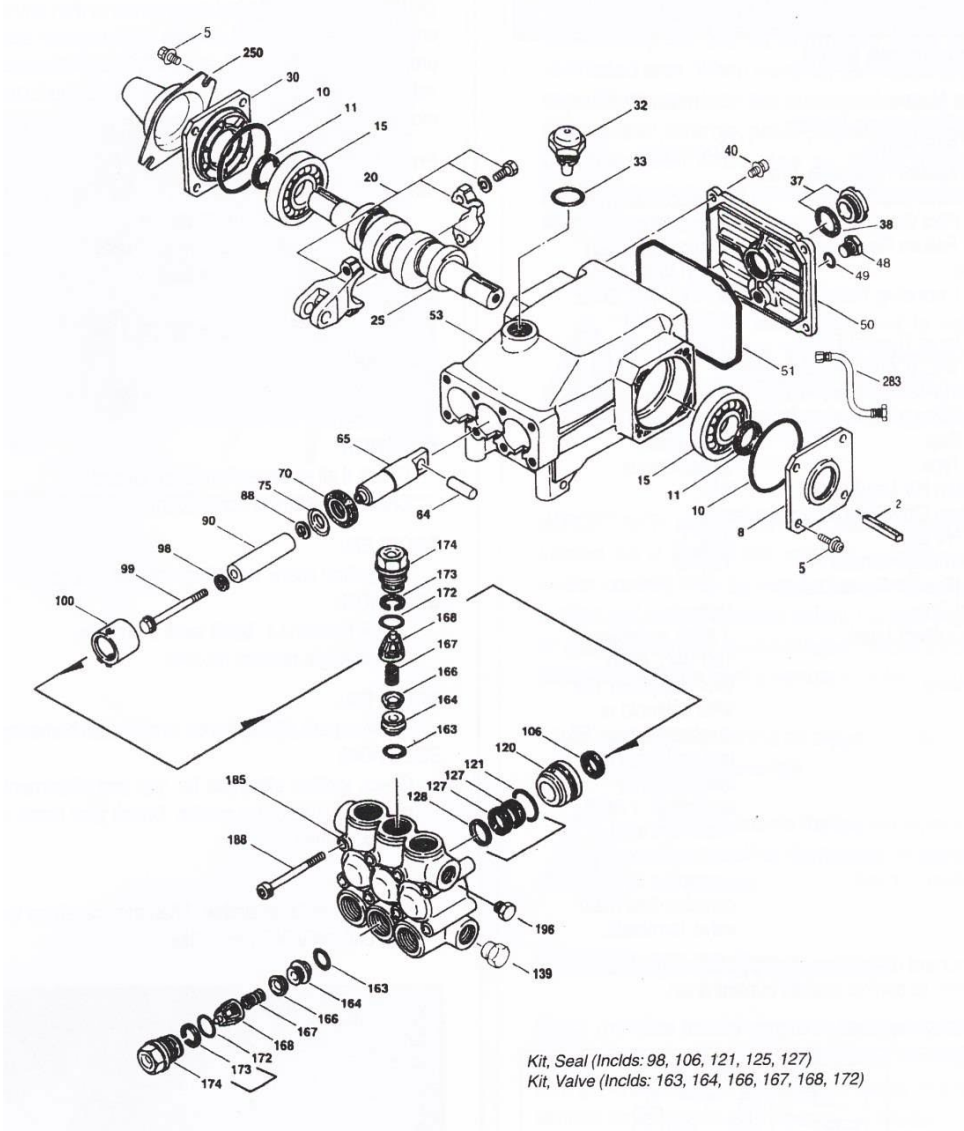

Figure 20: Pump exploded view

Pump parts list (5CP310, 5CP3120G1, 5CP3130G1)

Item	Part number	Material	Description	Quantity
2	30057	STL	Key (M6x6x25)	1
5	96031	STZP	Screw, Sems (M8x16)	8
8	46910	AL	Cover, Bearing	2/1
10	14028	NBR	O-ring, Bearing Cover -70D	2
11	43222	NBR	Seal, Oil, Crankshaft	2
15	14480	STL	Bearing, Ball	2
20	148658	HS	Rod, Connecting Assembly [2/00]	3
25	46928	FCM	Crankshaft, Dual End – 3120, 5120, 6120, 6120G1	1
	48233	FCM	Crankshaft, Single End – 31201G1	1
	48368	FCM	Crankshaft, Single End – 31201G1, 5150G1	1
30	48224	AL	Cover, Bearing Blind	1
32	46798		Cap, Oil Filler, Domed	1
33	14179	NBR	O-Ring, Bubble 2/Gasket – 80 D	1
37	92241		Gauge, Oil Bubble w/Gasket – 80 D	1
38	44428	NBR	Gasket, Flat, Oil Gauge – 80 D	1
40	92519	STZP	Screw, Sems (M6x16)	4
48	25625	STCP	Plug, Draign (1/4" x 19BSP)	1
49	23170	NBR	O-Ring, Drain Plug – 70D	1
50	46940	AL	Cover, Rear	1
51	14044	NBR	O-Ring, Rear Cover	1
53	48617	AL	Crankcase	1
64	46746	CM	Pin, Crosshead	3
65	48458	BBNP	Rod, Plunger	3
70	46838	NBR	Seal, Oil, Crankcase – 70D	3
75	43900	S	Slinger, Barrier	3
88	45697	S	Washer, Keyhole (M18)	3
90	46884	CC	Plunger (M16x50)	3
98	46730	NBR	Washer, Seal	3
	48394	FPM	Washer, Seal	3
99	48201	SS	Retainer, Plunger w/Stud (M6)	3

100	46749	PVDF	Retainer, Seal	3
106	43316	NBR	Seal, LPS w/S Spg	3
	106660	FPM	Seal, LPS w/S Spg	3
120	46888	BB	Case, Seal (Press-in-Style)	3
121	13978	NBR	O-Ring, Seal Case – 70D	3
	14329	FPM	O-Ring, Seal Case	3
125	-		Seal, HPS w/s	3
	-		Seal, HPS w/SS	3
127	43319	PTFE	V-Packing	6
	46287	HT	V-Packing	6
	-		V-Packing	6
128	46618	NY	Adapter, Male	3
139	22179	BBCP	Plug, Inlet (1/2" NPT)	1
162	-		Back-up-Ring, Seat	6
163	17457	NBR	O-Ring, Seat	6
	11685	FPM	O-Ring, Seat	6
164	46658	S	Seat	6
166	46429	S	Valve	6
167	43750	S	Spring	6
168	44565	PVDF	Retainer, Spring	6
172	17549	NBR	O-Ring, Valve Plug	6
	26996	FPM	O-Ring, Valve Plug	6
173	48365	D	Baku-up-Ring, Valve Plug	6
174	45900	BB	Plug, Valve	6
185	46886	FBB	Manifold, Head	1
188	87872	STZP	Screw, HSH (M8x70)	8
196	22187	BBCP	Plug, Discharge (3/8" NPT)	1
250	118672	STCP	Protector, Shaft	1

Gas Valve

Before attempting any service on the heater gas control valve, note that only the service procedures outlined in the manual are approved by the manufacturer. Replace the control valve if any other service or repair is required.

- Ensure the installer is a qualified serviceperson.
- Shut off the gas supply before starting installation or service.
- Do not connect the appliance before pressure testing
- To prevent damage to the thermostat, do not short the gas valve terminals.
- Do not grip control the body with a wrench or vise. Use the inlet boss only.
- Leak test after installation or service. With gas flowing through the control (main burner on), coat possible leak points (pipe and tubing joints gasket edges, etc.) with a soap solution. Bubbles indicate leaks.
- Always turn the gas cock dial to full “ON” setting. Do not use it to adjust gas flow.
- When changing from natural to L.P. gas or vice versa, the burner and pilot orifices must also be changed. Note that L.P. gas does not vent upwards naturally.

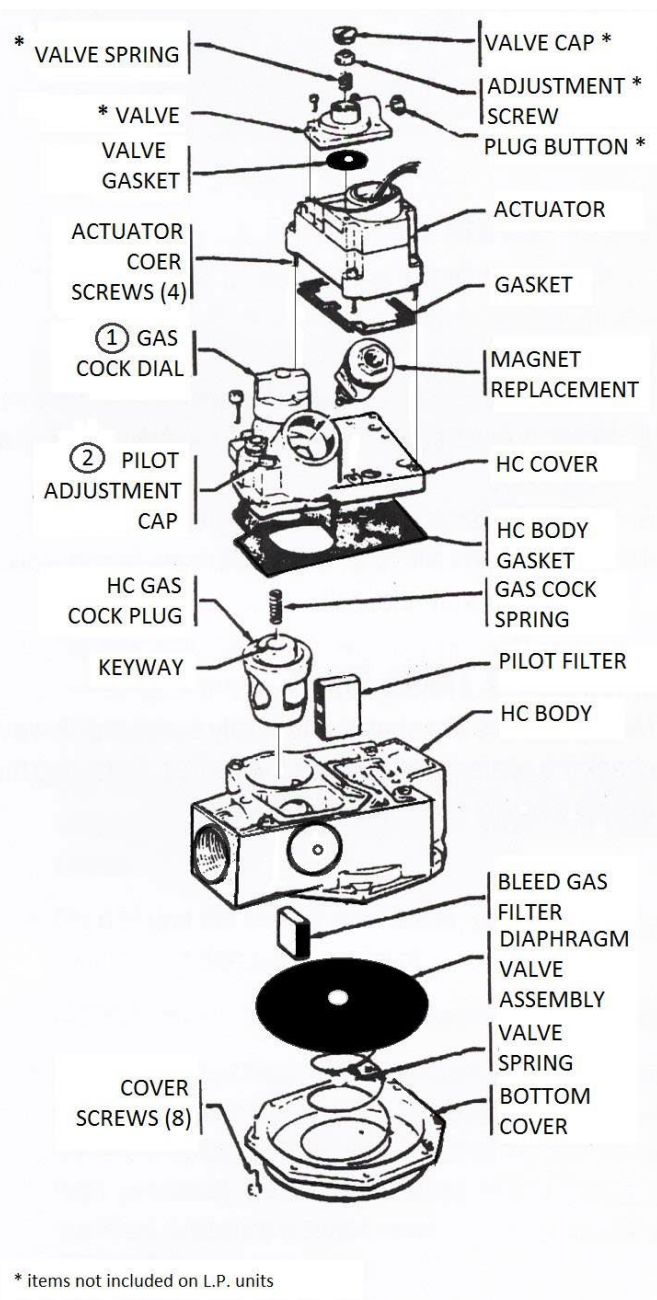

Figure 21: Gas Valve exploded diagram

Adjusting the pilot light

1. Remove the adjusting cap using a fine screwdriver.
2. The pilot flame should be about 1-inch high. Turn the pilot adjustment cap (screw) clockwise to make the pilot lower. Turn the pilot adjustment cap counterclockwise to make the pilot higher.

Troubleshooting



Warning: To prevent serious or fatal injury, ensure the machine is shutoff and disconnected from the electrical supply before attempting any repairs or maintenance. Use lockout-tagout procedures.

Troubleshooting is an organized study of the problem and a planned method of investigation and correction. The following troubleshooting guide includes some of the problems that you may encounter during service of the machine. It does not give all the possible methods to correct the problems listed, but is meant to stimulate a train of thought and indicate a work procedure directed toward finding the source of the problem.

Most problems are simple and easily corrected. To save time and trouble, always check the easiest and obvious thing first.

Study the problem thoroughly, and ask yourself these questions:

- What was the warning signs preceding the trouble?
- What previous repair and maintenance work has been done?
- Has a similar problem occurred before?
- If the machine still runs, is it safe to continue operation to make further checks?

Gas burner malfunction

Problem	Probable cause	Solution
Pilot will not light (temperature light does not turn on).	<ol style="list-style-type: none"> 1. Gas dial turned off 2. Gas leak 3. Low or High gas pressure 4. Air in gas line 5. Pilot adjustment screw needs readjustment. 6. Intermittent ignition <ol style="list-style-type: none"> a. Not working b. Weak or no spark c. Pilot solenoid not working d. Electrodes damaged or out of adjustment 	<ol style="list-style-type: none"> 1. Turn dial on. 2. Check fittings with soapy water, and tighten any loose fittings 3. Check the pressure with a manometer. If LPG pressure is low, the cylinder may be empty or “cold. If natural gas pressure is low, the supply pipe may be too small or the gas supply is inadequate. 4. Vent through the open hose, and then reconnect to the burner (allow ample time for the air to escape). 5. Adjust the flame to reasonable size. 6. (also see the table for the intermittent ignition device below) <ol style="list-style-type: none"> a. Check or replace ignition harness and electrodes, which are located under the burner. Check voltage supply to electronic module b. Check power supply or voltage c. Replace solenoid d. Readjust or replace.
Pilot will not stay lit	<ol style="list-style-type: none"> 1. Draft extremes 2. Defective electrode 3. Undersized gas supply pipe or hose resulting in a wide swing in gas pressure in burner on/burner off 4. intermittent ignition <ol style="list-style-type: none"> a. Defective ignition electrode wire connection or electrode. b. Module defective c. Electrode out of adjustment 	<ol style="list-style-type: none"> 1. Install a draft diverter (see the Installation section), or relocate the machine to a less drafty area, or provide shields or walls to isolate the burner. 2. Replace electrode 3. Install a larger gas supply hose. 4. Adjust the flame to reasonable size. 5. Fix intermittent ignition as follows: <ol style="list-style-type: none"> a. Repair b. Replace c. Adjust
Burner will not light	<ol style="list-style-type: none"> 1. No fuel 2. Pilot out 3. Thermostat set too low. 4. Faulty thermostat 5. Burner control circuit dead 6. Flow switch faulty 	<ol style="list-style-type: none"> 1. Natural gas: open supply line valve; L.P.: open valve or install new bottle 2. Turn burner switch off, and then back on. 3. Reset thermostat. 4. Check continuity with high-voltage tester and test light. Replace if faulty 5. Check for loose connection or broken wires. Reestablish power. 6. Check switch for continuity. Replace if necessary.
Burner smokes	<ol style="list-style-type: none"> 1. Inadequate draft or combustion air 2. Dirty or clogged gas jet 3. High gas pressure 	<ol style="list-style-type: none"> 1. Contact a qualified heating expert to check for chimney draft or combustion air. 2. Contact a certified service technician. 3. Contact a certified service technician
Burner fails to turn on and off with operation of wand trigger	<ol style="list-style-type: none"> 1. Flow switch faulty 2. Faulty gas valve 	<ol style="list-style-type: none"> 1. Hold the trigger on the gun open, and shut the burner switch off and turn pump switch off to relieve pressure. Continue to hold the trigger until the burner extinguishes, and then turn the Pump switch off. Contact a certified service technician 2. Contact a certified service technician.
Low temperature output	<ol style="list-style-type: none"> 1. Low gas supply pressure 2. Thermostat set to low 	<ol style="list-style-type: none"> 1. Contact a gas service person. 2. Increase the thermostat setting.

	<ol style="list-style-type: none"> 3. Limed up heating coil. 4. Burner control circuit faulty keeping gas valve closed. 5. Low temperature tap water 	<ol style="list-style-type: none"> 3. Descale the unit. 4. Check the circuit for loose wiring. Reestablish power. 5. Increase water temperature.
Excessive temperature output	<ol style="list-style-type: none"> 1. Temperature set too high 2. Faulty thermostat 3. Excessive gas pressure 4. Flow switch malfunction 	<ol style="list-style-type: none"> 1. Decrease thermostat setting. 2. Replace thermostat. 3. Recheck pressure. 4. Replace bad flow switch

Intermittent ignition device problems

Problem	Probable cause	Solution
No ignition spark	<ol style="list-style-type: none"> 1. No voltage to module 2. No voltage at pilot gas valve 3. Spark wire grounded out 4. Pilot grounding out 	<ol style="list-style-type: none"> 1. Ensure all safety switches are closed. Check all electrical connections. 2. Ensure all safety switches are closed. Check all electrical connections. 3. Follow spark wire and check for bare wires grounding to frame 4. Drop down pilot and test for spark. If sparking down, reinstall into burner ring and make sure it is not touching a burner orifice.
Erratic main burner operation, but the ignition sparks, and the pilot flame is on	<ol style="list-style-type: none"> 5. Ignition electrode needs adjustment or is not grounded 6. Insulator cracked 7. Pilot flame erratic 	<ol style="list-style-type: none"> 5. Check the ignition electrode for gap and placement. 6. Check the ceramic insulator for cracks. 7. Check the pilot flame for flutter. Check the ground.

Pump malfunction and pressure delivery problems

Problem	Probable cause	Solution
Low pressure	<ol style="list-style-type: none"> 1. Worn or oversize spray nozzle 2. Clogged water inlet strainer 3. Out of detergent (pump sucking air through detergent line) 4. Air leak in inlet plumbing 5. Belt slipping 6. Dirt or foreign particles in the valve assembly 7. Worn or damaged inlet or discharge valve. 8. Inline filter plugged 9. Coil scale 10. Faulty unloader 	<ol style="list-style-type: none"> 1. Replace worn nozzle. 2. Clean or replace fouled strainers (in float tank). 3. Restore detergent supply or close detergent shut-off valve. 4. Locate air leak. Reseal connection or replace damaged part. 5. Tighten or replace if damaged. 6. Remove any dirt or particles. 7. Replace worn valves. 8. Clean inline filter, or replace if damaged. 9. Descale coil. 10. Replace unloader assembly.

Rough operation with loss of pressure	<ol style="list-style-type: none"> 1. Restricted inlet plumbing or air leak in inlet plumbing 2. Damaged pump parts 3. Damaged vacuum switch 4. Float tank running empty 	<ol style="list-style-type: none"> 1. Ensure adequate water supply and supply hose. Repair clogged inlet fittings. 2. Replace any damaged pump parts clean out any foreign particles. 3. Replace vacuum switch. 4. Check incoming water supply, replace float assembly if water not keeping up to demand
Water leakage in intake manifold or crankcase	Worn manifold seals or condensation inside the crankcase	Replace seals. Change the oil on a regular basis.
Noisy operation, knocking	<ol style="list-style-type: none"> 1. Inadequate water supply to the pump, creating a "vacuum knock" 2. Loose pulley 3. Worn or broken bearing(s) 4. Faulty pump shaft 	<ol style="list-style-type: none"> 1. Check for restricted inlet and adequate tap water supply. 2. Check key and tighten set screw. 3. Replace bearing(s). 4. Replace pump.
Oil leaks	Worn crank seals, crankcase cover and seal or drain plug	Replace seals.
Excessive pump shaft play	Worn and loose bearings	Replace bearings. Check bearing seals, spacers and retainers, replacing any worn parts.
Irregular spray pattern	Worn or partly clogged spray nozzle	Clean or replace nozzle.

General malfunctions

Problem	Probable cause	Solution
Machine cycles	<ol style="list-style-type: none"> 1. Chemical injector clogged 2. Nozzle clogged 3. Filter clogged 4. Air leak 5. Clutch engaging when trigger not pulled 	<ol style="list-style-type: none"> 1. Replace the chemical injector. 2. Disassemble the nozzle and clean the elements. 3. Clean or replace the filter (see the maintenance section). 4. Locate air leak and repair. 5. Check for leaks in plumbing from hoses, coil, and nozzle. Repair leak if found, if no leaks found, replace unloader valve.
Machine pulsates two to three times per second	Broken valve in the pump	Remove and replace pump valve (see the Repair section).

Chemical system malfunction

Problem	Probable cause	Solution
Injector(s) won't draw	<ol style="list-style-type: none"> 1. Plugged wand nozzle 2. Damaged wand nozzle 3. Chemical pick-up filter clogged 4. Injector clogged 5. Hose damaged 6. Not adequate flow/pressure 7. Temperature too high 	<ol style="list-style-type: none"> 1. Clean or replace nozzle. 2. Replace nozzle. 3. Check – clean or replace. 4. Remove and clean injector. 5. Replace hose. 6. See low pressure section. 7. Turn thermostat down.
Injectors fade in and out	Water temperature too high	Turn down temp dial to 150 degrees or less. If nothing changes, replace bad temp controller

Electrical malfunction

Problem	Probable cause	Solution
Washer electrically dead	<ol style="list-style-type: none"> 1. No power to machine 2. Defective Pump switch 3. Faulty or loose wiring 	<ol style="list-style-type: none"> 1. Check the circuit breaker. Check for a defective electrical outlet. 2. Test the switch, and replace if it is defective. 3. Contact qualified service technician.
Power supply circuit breaker trips often, will not stay on	<ol style="list-style-type: none"> 1. Short circuit in the washer or elsewhere on the circuit 2. Undersized circuit used, or too much total load on the circuit. 3. Supply voltage is too low 	<ol style="list-style-type: none"> 1. Check washer (and other loads on the same circuit) for faulty or loose wiring. 2. Put the washer on a larger circuit, or remove the loads from the existing circuit. 3. 220 V requires 208 V. Check the line voltage, and connect the washer to an adequate voltage supply.
Thermal overload protector in main pump motor trips often	<ol style="list-style-type: none"> 1. Partially or totally clogged spray nozzle overburdens the motor 2. Undersized spray nozzle in use 3. Restriction in plumbing of the machine 4. High ambient temperature 5. Supply voltage is low 	<ol style="list-style-type: none"> 1. Remove and clean out the nozzle. Make sure the strainers on the inlet and chemical suction tube are present and in good, clean condition. 2. Make sure the nozzle size is as given in the Specifications section. 3. Locate restriction and repair. 4. Install better ventilation, or move to a cooler location. 5. Check the line voltage and ensure proper voltage.
Electrical shock from cabinet and spray wand	Electrical leakage exists, and the machine is not properly grounded	 <p>Danger: To prevent injury or death, do not use the machine. Find the problem or contact a qualified electrician. Ensure the machine is completely grounded at all times. This means a solid ground connection inside the cabinet.</p>

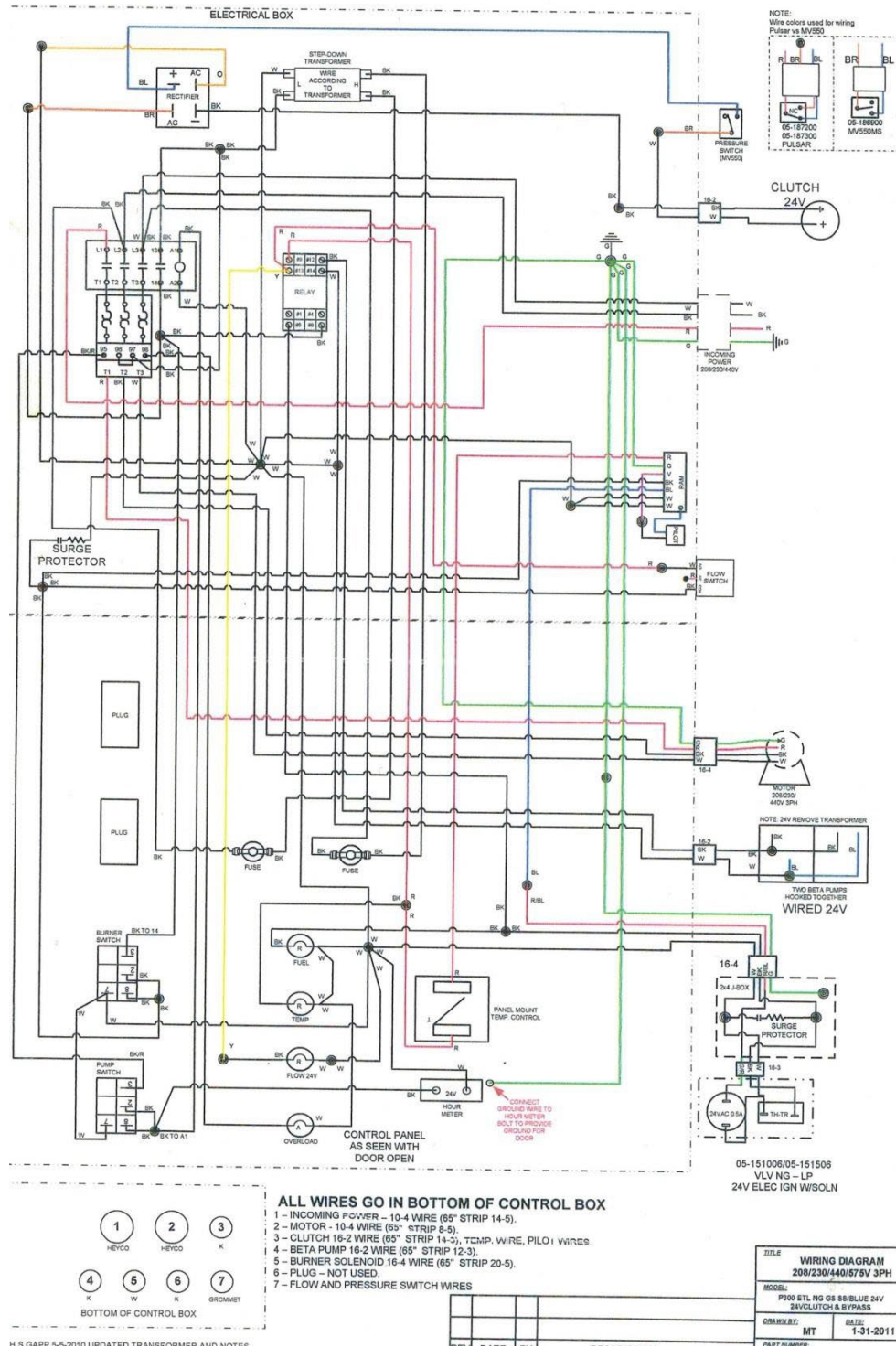

Figure 22: Electrical diagram



PEM Corporation
888-969-1601
sales@pemequip.com

PEMequip.com